

CASTER KIT FITTING INSTRUCTIONS

Kit:

4 steel outer eccentric bushes.

Tools Required:

Garage press

Torque wrench & suitable spanners & sockets

1. After raised suspension system has been fitted, and while vehicle is on a flat surface mark the vertical through the centre of the front original bush at 90° to the horizontal line on each leading arm. Refer fig .1

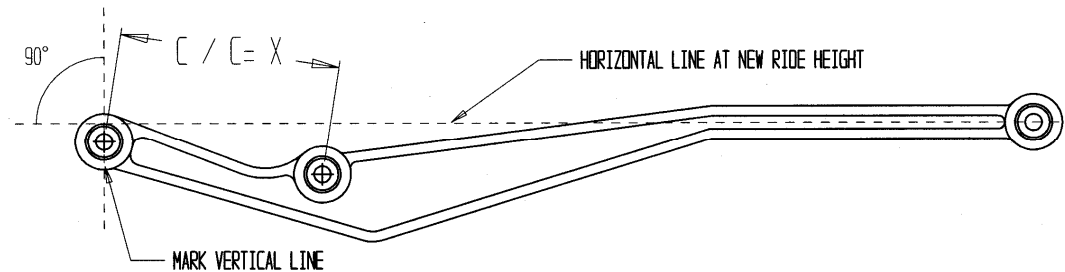

Fig.1

2. Note down the measurements between the centre of the two front original bushes on each arm. ($c / c = x$)
3. Remove front leading arms from vehicle and press out the two front bushes of each arm.
4. Align the OME caster kit bush in the front hole of the leading arm ensuring the raised indicator mark on the bush is pointing **DOWN** towards the previously marked vertical line.
5. Press bush into leading arm. Refer fig .2

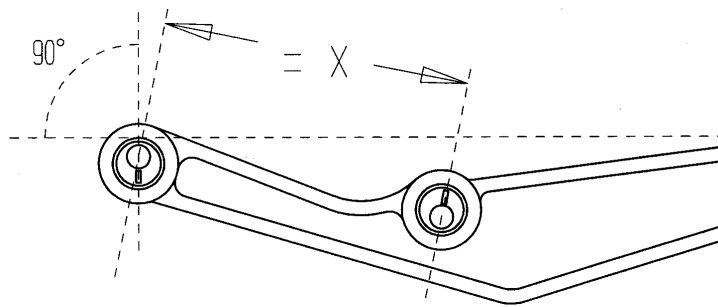

Fig .2

6. Install the second bush by positioning the bush pin centre at the same centre spacing ($= x$) previously taken from the original bush centres.
Note: The raised indicator mark on the OME caster kit bush must face **UPWARD**. Refer fig .2
7. Refit leading arms and torque retaining bolts to manufacturer's specification. Thread sealant should be used. eg Loctite 262

NOTE: The manufacture recommends the leading arm retaining bolts are not reused.

Bolts must fit freely into the caster bushes. If bolts don't fit freely remove bushes and refit.